



WINDSTREAM WHOLESALE INNOVATES WITH MANAGED SPECTRUM

Success Story

About Windstream Wholesale

Windstream Wholesale is an innovative optical technology leader who creates deep partnerships with carriers and content and media providers to deliver flexible, customized solutions.

To learn more about Windstream Wholesale, visit us at windstreamwholesale.com

WINDSTREAM WHOLESALE





At Windstream Wholesale, we've listened to our customers' feedback; and they continually express their needs for network flexibility, agility, control, and cost optimization. Recently, we've seen an increased demand from customers looking to build and manage private networks in-house, however for customers to do this effectively on their own, it may not be as easy as it seems. There are many significant prohibiting factors which include cost (capital for equipment and fiber) as well as the operational staff needed for both field operations and customer support.

We've heard our customers and have been working on developing a new technology offering we're calling Managed Spectrum.

What is Managed Spectrum?

Managed Spectrum provides a block of photonic capacity measured in GHz to interconnect two locations within a metropolitan area, or across the country. The unique benefit to our customer is that it provides the scalability of dark fiber without the capital costs or operational overhead of building, managing, and maintaining a fiber network.

The customer gains flexibility by having the ability to reserve blocks of spectrum to utilize as their network capacity needs grow (“pay as you grow” scalability).



Managed Spectrum Topology

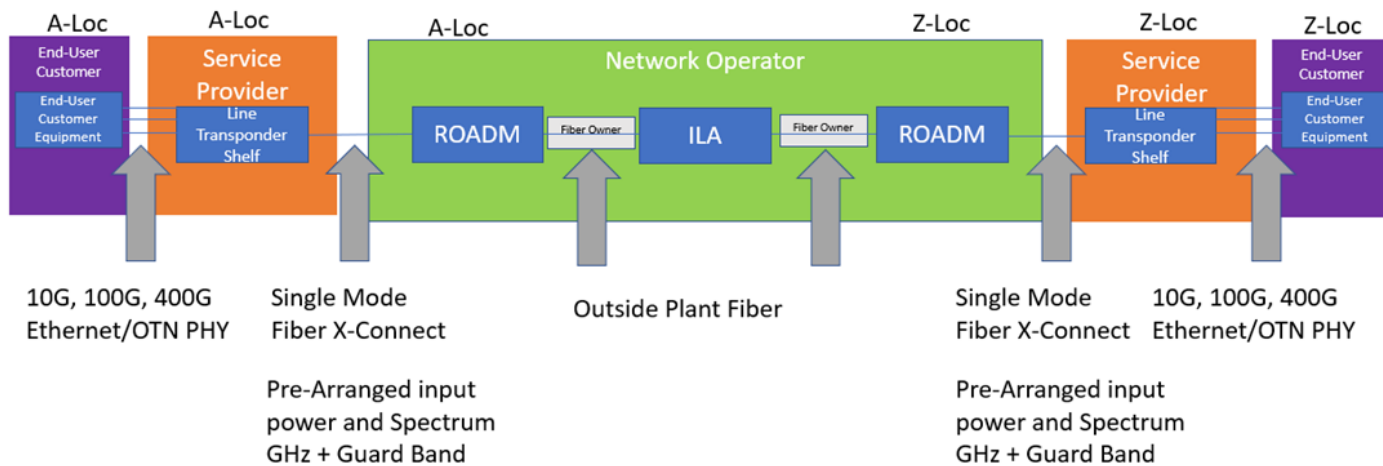

Our First Successful Trial: Proof of Concept

In mid-March of this year, Windstream and Colt Technology Services successfully trialed a WIN Managed Spectrum solution. As pictured below, WIN provided an optical line system spanning nearly 1800 km between Chicago and Ashburn, Virginia. Colt deployed and connected their own optical transponder equipment to provide their own wave lengths over the system, and they were able to utilize that spectrum to provision multiple 100G and 400G services on that route.

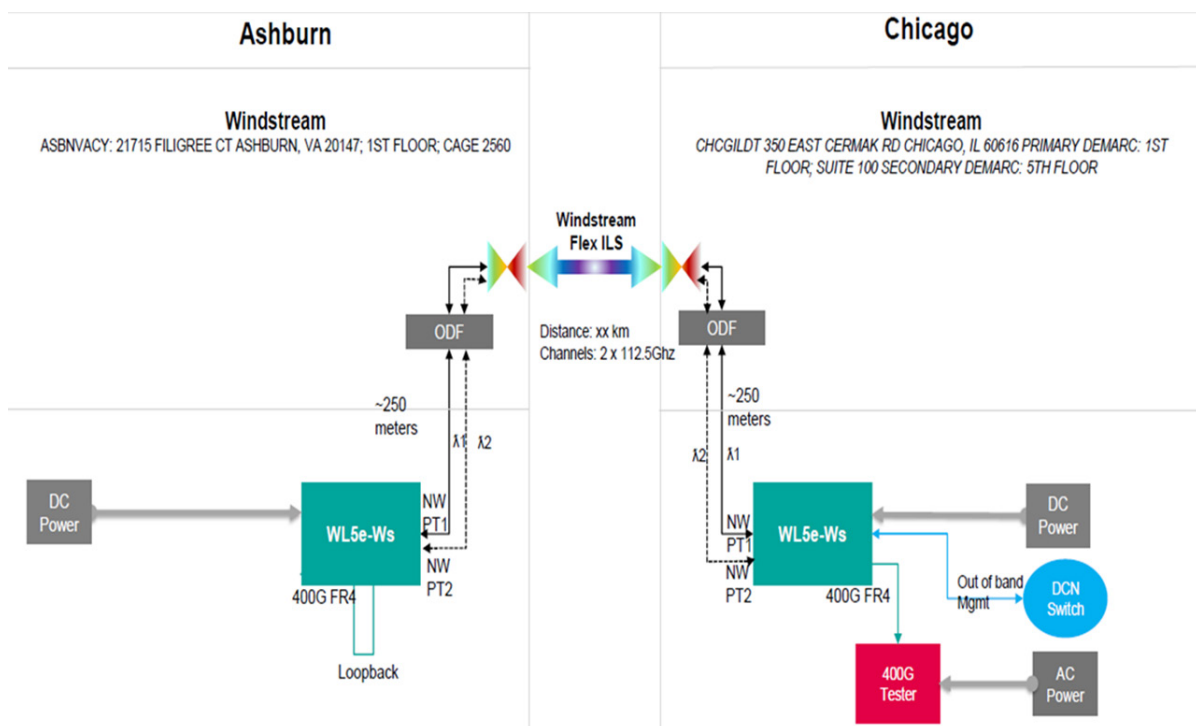

Along with the line system, Windstream also presented key performance metrics of the transmission network, a concept known as Layer Zero Analytics, through the Windstream Wholesale customer portal.

Layer 0 Analytics Metrics as displayed to customer in Windstream portal



Layer 0 Analytics			
Location A		Location Z	
CLLI:	CHCGILDT	CLLI:	ASBNVACY
Date Time:	2021-04-01 13:00:00 UTC	Date Time:	2021-04-01 13:00:00 UTC
OSNR (dB):	21.7	OSNR (dB):	21.8
DGD (ps):	3	DGD (ps):	2
CD (ps/nm):	14950	CD (ps/nm):	14943

CHCGILDT - past 30 days

ASBNVACY - past 30 days

CHCGILDT - past 30 days

ASBNVACY - past 30 days

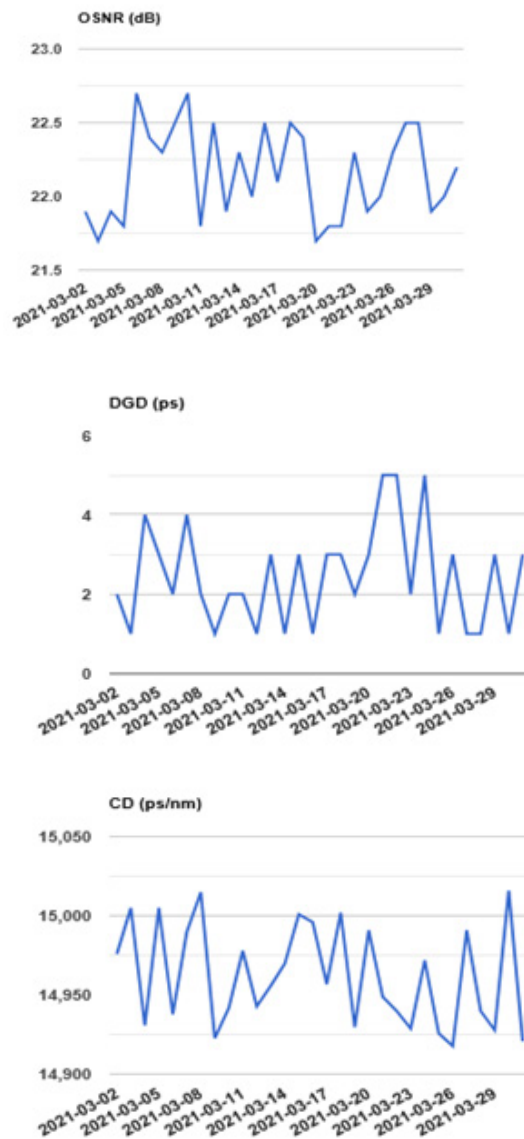
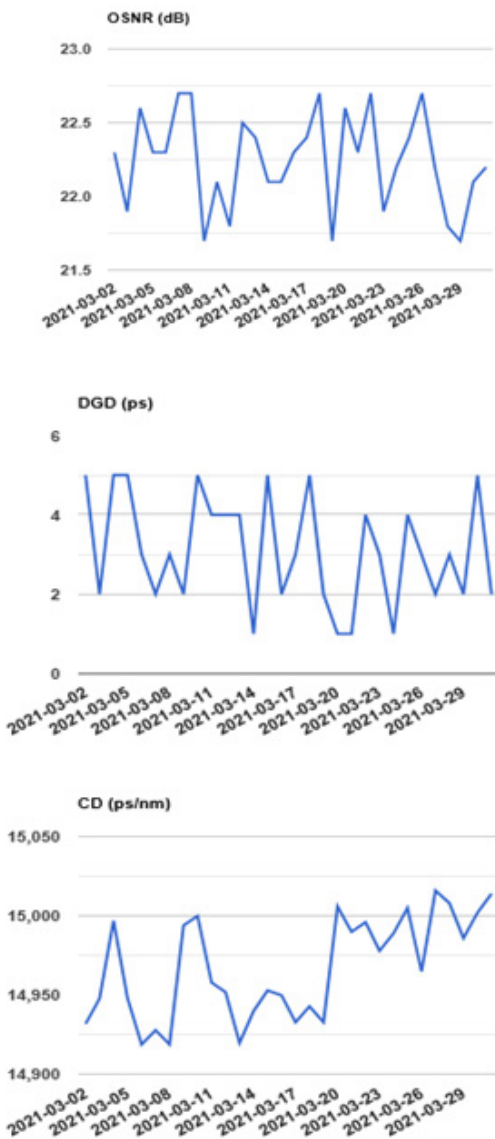



The Results

The successful trial of WIN Managed Spectrum means increased functionality and superior scalability for our customers seeking independence, flexibility, agility, and cost controls.

By providing these types of self-diagnostic metrics, customers are able to independently plan coherent wavelength deployments, self-diagnose service performance, and assess the health of their network 24/7, as if they were the owner/operator of the open optical line system.

Since successfully achieving positive results with the technology, we now have established proof of concept. As a result of our trial, Windstream Wholesale is now formally developing and entering the commercialization phase of a Managed Spectrum product offering with the express goal of launching later in 2021.

At Windstream Wholesale, our innovative technology leadership continues every day. We are extremely excited about the momentum and opportunities that Managed Spectrum will bring to Windstream and our customers.

Windstream Wholesale:

We care.

We listen.

We solve customers' needs.

To learn more about Windstream Wholesale, visit us at windstreamwholesale.com

Call 1-866-375-6040